

Mesh Potato
Small Enterprise / Campus Network
User Guide





SECN User Guide by T L Gillett is licensed under a
[Creative Commons Attribution-ShareAlike 3.0 Unported License](https://creativecommons.org/licenses/by-sa/3.0/).
Based on a work at www.villagetelco.org.

Acknowledgements

This work would not have been possible without the contributions of many people associated with Village Telco. In particular I would like to acknowledge the considerable contributions made by Elektra both in providing technical guidance and in building the software, as well as writing the text for sections of this manual. I would also like to acknowledge the ongoing support and encouragement provided by Steve Song.

Note: This draft document is intended to be read in conjunction with SECN rv287 firmware.

Table of Contents

1. Introduction.....	4
2. A Simple Mesh Set Up.....	5
3. Example Networks.....	6
4. Setting Up MP Devices.....	8
4.1 Installing the SECN Firmware.....	8
4.2 Minimum Set-up.....	14
4.4 Set-up Using SECN Web Interface.....	15
4.4 Set-up using OpenWRT Web Interface.....	22
4.5 Advanced Set-up.....	25
5. Overview of SECN Operation	29
5.1 IP Address Range for MPs.....	29
5.2 Batman-Advanced Operation.....	30
5.3 Telephony Operation.....	33

1. Introduction

The Small Campus Enterprise Network firmware is designed to allow a collection of Mesh Potato (MP) devices to provide a data and telephony network for a small campus.

The intended use is typically for a small/medium size organisation which needs to set up a number of workpoints spread over a limited geographic area, with each workpoint being equipped with a telephone and a networked PC, and to do this wirelessly without using conventional LAN cabling.

The meshed MP devices utilise an OSI Layer 2 protocol and simply act as one large switch, transparently connecting all the attached devices together.

Each MP device provides a telephone connection, an Ethernet cable connection, and a WiFi Access Point. PCs and other network devices may be connected to the Ethernet port of an MP, or connect wirelessly to the WiFi Access Point of each MP.

The WiFi access point is encrypted with WPA by default in order to provide some protection from abuse of the data network as long as the pass phrase/key is kept confidential.

If one or more of the MP devices is connected via its Ethernet port to a LAN with a router / DHCP server and Internet access, any PC connected either by Ethernet cable to an MP or by WiFi, will be able to acquire a DHCP address on the LAN and connect to the Internet via the router.

Similarly, networked devices such as printers or storage devices may be attached to the LAN via an MP. All attached devices will appear on the LAN and will be visible to each other.

Each MP device provides a telephone port which may be called from another MP telephone by dialling the IP address of the required device. Abbreviated dialling is also supported so that a call may be made by dialling just the last octet of the required IP address.

To use telephony off the local mesh, individual MPs can be configured to access a SIP/VoIP Service Provider account for outgoing and incoming calls.

Configuration and management of individual MP devices is possible via telephone IVR commands, browser or terminal sessions with access to the underlying Linux operating system and OpenWRT software.

2. A Simple Mesh Set Up

In this simple mesh network we will set up a network of two MP devices so that phone calls can be made between them, then connect one MP to a Local Area Network with Internet access so that a laptop can connect wirelessly to the virtual Access Point and access the LAN and Internet.

Step 1. Flash the MP devices to the SECN firmware rv278.
See following section for details of how to flash the devices.

Step 2. Set the unique IP address for each MP device.

When the MP devices are rebooted, connect a telephone.

Lift the receiver and check for dial tone.

Dial **2662** and when the announcement has finished dial **21**.

Wait to hear the number being read back, then the device will reboot itself.

Repeat the process with the second MP, but dial **22** and wait for it to reboot.

The MP devices are now set to IP addresses **10.130.1.21** and **10.130.1.22** respectively. It may be useful to label the devices as '21' and '22'

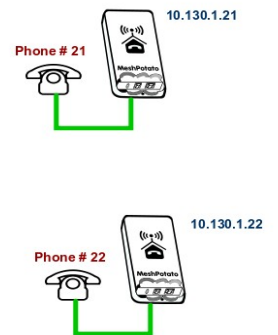

Step 3. Make a phone call.

After the MP devices have fully rebooted (allow a couple of minutes after the WiFi light starts to flash), pick up the phone on the '21' MP, check for dial tone and dial 22. The other phone should start to ring after a few seconds. Repeat the other way around.

Step 4. Attach the mesh network to your LAN.

Connect the MP '21' to a spare port on your router with an Ethernet cable. The diagram shows the LAN using an IP address range of 192.168.1.xxx, but the actual range used will not matter

Note:– Because the mesh utilises an OSI Layer 2 protocol, it will work with any LAN address range. The MP addresses do *not* have to be in the same subnet as the LAN in order for the mesh to carry LAN data traffic.

Step 5. Attach a Laptop via WiFi.

Your laptop should be able to see a WiFi Access Point called Mesh-Potato-AP secured with WPA encryption. Connect to this Access Point with a WPA password of '**potato-potato**' and using Automatic assignment of IP address (DHCP).

Your laptop should acquire an IP address in the range offered by your LAN router, and you should be able to access the Internet.

You should be able to make calls between the MP devices while accessing the Internet on the laptop.

You can connect another PC to the '22' MP using an Ethernet cable and it will similarly acquire an IP address from the router.

The laptop and PC should be able to access any other devices on the LAN, such as printers or network storage devices just as if they were connected directly to the LAN.

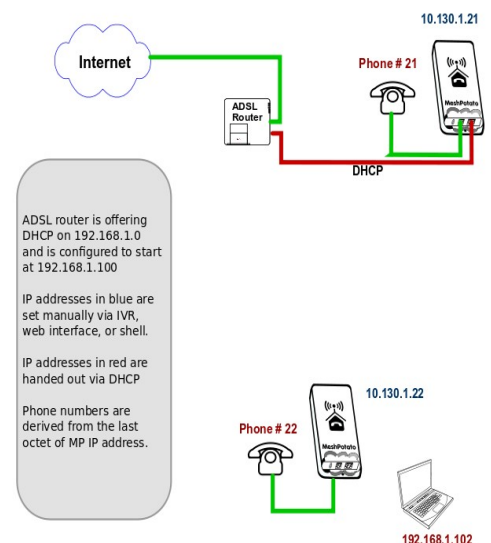

3. Example Networks

Following are examples of practical networks built around MP devices operating in a mesh.

Network 1

In this network, MP devices have been assigned static IP addresses that are part of the LAN address space, 192.168.1.xxx, and appropriate Gateway and DNS addresses.

This means that the MP administration interfaces (LUCI web interface and *ssh* command line) will be accessible from any workstation connected to the LAN.

When a workstation is attached to the mesh network either by Ethernet cable or WiFi, it will acquire an IP address from the router in exactly the same manner as if it was connected directly to the router.

The router address space must be managed so that there is no conflict between the statically assigned MP addresses and those for any other device on the network. In this example the router offers DHCP addresses starting at 192.168.1.100, while the MPs have been assigned static addresses below this range.

Phone calls may be made between MP devices either by dialling the last octet of the required MP address (e.g. '10'), or by dialling the full address (e.g. '192*168*1*10').

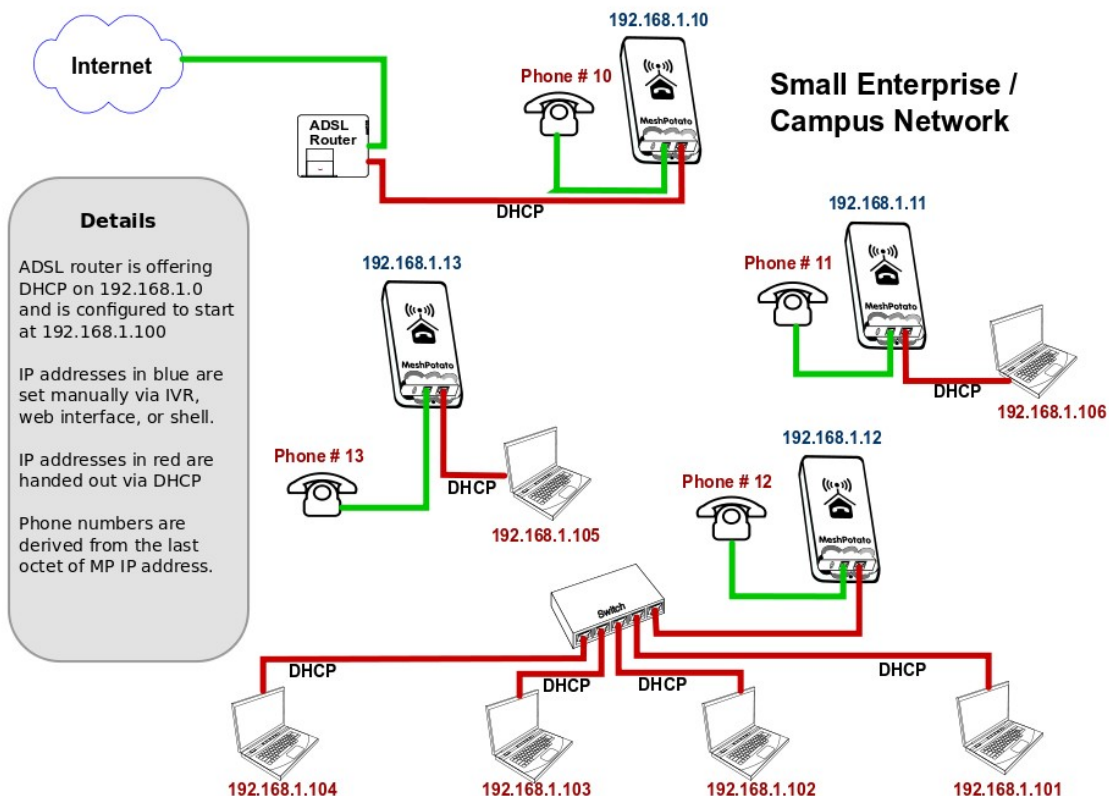

Network 2

In this network, MP devices have been assigned static IP addresses that are not part of the LAN address space. Instead they have been assigned IP addresses in the default address space 10.130.1.xxx.

This means that the MP administration interfaces (LUCI web interface and *ssh* command line) will not be accessible from workstations connected to the LAN with IP addresses assigned in the LAN address space.

Administration of the MP devices may be undertaken from a workstation assigned a static address in the same range as the MP devices and attached via Ethernet cable or WiFi to any MP device in the network.

When a workstation is attached to the network either by Ethernet cable or WiFi, it will acquire an IP address from the router in exactly the same manner as if it was connected directly to the router.

In this example there is no need to manage the LAN address space to allow for the MP addresses as they are allocated in a completely different address space (10.130.1.xxx).

Phone calls may be made between MP devices either by dialling the last octet of the required MP address (e.g. '10'), or by dialling the full address (e.g. '10*130*1*10').

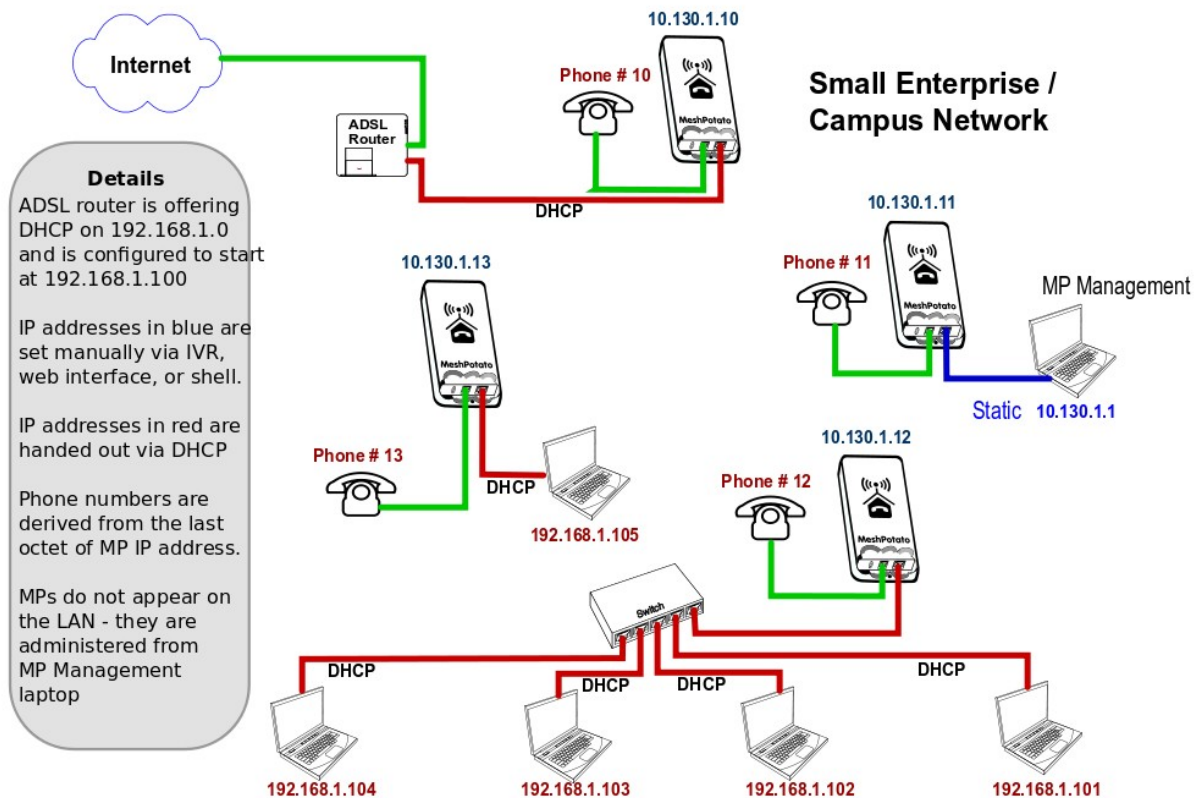

4. Setting Up MP Devices

This section describes how to set up MP devices for use on your mesh network.

The first step is to install the SECN firmware on the MP device.

After installing the firmware, three different methods are available to configure the device:

- **Minimum Setup** using telephone Interactive Voice Response (IVR)
- **Basic Setup** using the web browser interface.
- **Advanced Setup** using a *ssh* terminal session and command line.

4.1 Installing the SECN Firmware

If you have purchased a new MP device, it will normally be delivered from the factory with firmware version rv233 installed. To operate with the SECN configuration, you will need to flash the MP with the SECN firmware (currently rv287).

There are three methods for installing the firmware:

- Use the *Potato-Flash* utility on a Linux PC connected to the MP via Ethernet cable.
- Use the OpenWRT *LuCI* web interface.
- Use the *sysupgrade* utility from the command line on the MP device.

Using the *LuCI* web interface or the *sysupgrade* utility has the advantage that the firmware can be installed on the MP without the need to connect with an Ethernet cable which may avoid the need to recover the device from an installation.

NOTE: Early MP devices may not be suitable for flashing with LuCI web interface or the sysupgrade utility until they have been flashed once with the potato-flash utility. This is due to an incorrect memory layout from a different flashing program. If possible, use the potato-flash utility as the preferred way to flash the MP device.

To check the status of your MP, run the command:

```
cat /proc/mtd
```

The correct output looks like:

```
dev:   size  erasesize  name
mtd0: 00030000 00010000 "RedBoot"
mtd1: 000b0000 00010000 "vmlinux.bin.17" Note that mtd1 contains the Linux kernel
mtd2: 006f0000 00010000 "rootfs"
...
```

An incorrect output may look like this:

```
dev:   size  erasesize  name
mtd0: 00030000 00010000 "RedBoot"
mtd1: 006f0000 00010000 "rootfs" Note that mtd1 does not contain the Linux kernel
mtd2: 00410000 00010000 "rootfs_data"
...
```

Installing with the Potato-Flash Utility

These instructions assume that you are running Ubuntu or other Linux distribution on your PC. If this is not the case, use one of the other methods.

1. Set up the *potato-flash* application on your PC

Download the potato-flash file from:

<http://elektrad.info/download/MESH-POTATO/potato-flash>

Save the file into */usr/local/bin*

Make the file executable:

chmod +x /usr/local/bin/potato-flash

2. Download the firmware

Download the required firmware from:

<http://elektrad.info/download/MESH-POTATO/>

Download the *.img .squashfs .lzma* files for the *rv287* firmware version and save to a working directory.

3. Set up networking on your PC

This step will ensure that *potato-flash* has proper access to the PC Ethernet network port.

Connect the MP directly to your PC with an Ethernet cable **with the MP power off**.

In Ubuntu Gnome desktop, right click on the Network Manager icon and deselect ***Enable Wireless***

Left click on the Network Manager icon and ***Disconnect*** any ***Wired Network*** that is active.

4. Flash the MP

Refer to the general instructions in ***Upgrading Mesh Potato Firmware HowTo*** on the Village Telco Wiki. Following is a brief description of the flashing process.

- Connect the MP directly to your PC with an Ethernet cable with the MP power **off**
- Execute potato-flash:
\$ sudo potato-flash eth0 openwrt-atheros-root-rv287.squashfs openwrt-atheros-vmlinux-rv287.lzma
- Wait for the program to start looking for the MP device - a series of dots will appear on the screen.
- Switch the power **on** to the MP.
- Wait for the flashing process to complete and for the MP to fully restart.
This may take a couple of minutes. This is a good time to have a coffee.
- Wait for three minutes after the MP WiFi led starts to flash to ensure that flash is complete.

Sample MP Flash Session

```
$ sudo potato-flash eth0 openwrt-atheros-root-rv238.squashfs openwrt-atheros-vmlinux-rv238.lzma
```

```
Reading rootfs file openwrt-atheros-root-rv238.squashfs with 3801088 bytes ...
```

```
Reading kernel file openwrt-atheros-vmlinux-rv238.lzma with 720896 bytes ...
```

```
Note: The device has to be connected directly (not via switch/hub)
```

```
Device detection in progress.....
```

```
<<< Turn the power to the MP device ON at this point >>>
```

```
.....device detection: non-arp packet received..
```

```
Peer MAC: 00:09:45:58:1c:e7
```

```
Peer IP : 192.168.1.184
```

```
Your MAC: 00:ba:be:ca:ff:ee
```

```
Your IP : 192.168.1.0
```

```
Connecting to Redboot bootloader
```

```
WARNING: UNPLUGGING POWER WHILE FLASHING MIGHT DAMAGE THE BOOTLOADER
```

```
HOWEVER: IF YOU SEE NOTHING SHOWING UP BENEATH THIS LINE
```

```
FOR MORE THAN A MINUTE, START AGAIN...
```

```
A flash size of 8 MB was detected.
```

```
rootfs(0x006a0000) + kernel(0x00100000) + nvram(0x00000000) sums up to 0x007a0000 bytes
```

```
Setting IP address...
```

```
Initializing partitions...
```

```
Now uploading kernel...
```

```
Sending kernel, 1408 blocks...
```

```
Flashing kernel...
```

```
Loading rootfs...
```

```
Sending rootfs, 7424 blocks...
```

```
Flashing rootfs...
```

```
Flashing process completed...
```

```
Restarting device...
```

Installing with the LUCI Web interface.

Download the MP device firmware as described in the previous section. The *.img* file will be used to install via the web interface.

If you are using a new MP it will operate with IP addresses of 10.130.1.20 (LAN) and 172.31.255.254 (Fallback). To use one of these addresses, configure your PC Ethernet network profile with a static address to be able to access either of these addresses, (eg to use the MP Fallback IP address, set the PC to IP: 172.31.255.253 Netmask: 255.255.255.252) and connect directly with an Ethernet cable to the MP device.

Alternatively you may set the MP device address to work on your LAN. Connect a telephone to the MP and dial the IVR command **C-O-N-F** (2663) and follow the prompts to set the IP number to one that lies in your normal LAN address range and is not already in use. The device will then reboot. Connect the MP device to an Ethernet port on your LAN and it will be accessible by any PC on the LAN.

Connect to the MP address with a web browser on your PC and you should see a login screen. Note the firmware version will be displayed in the upper right of the page – r277 in this example. For a new MP device the password for the root account will be blank. Click the **Login** button.



Select the **System** menu and the **Flash Firmware** item

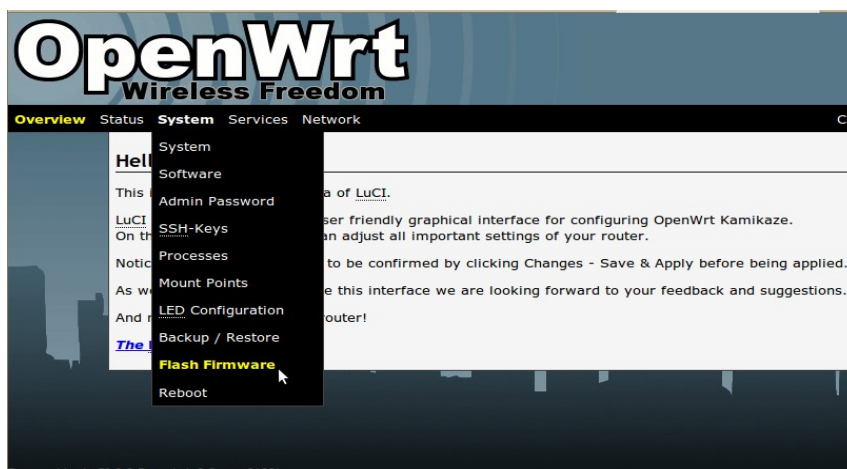

When the *Flash Firmware* page appears, click on the *Browse* button and select the required *.img* file from your PC file system.

Click on the *Upload* image button. The firmware will be loaded into MP via the web browser.



When the file has been uploaded, the *Checksum* and *Size* details will be displayed.

Click on the Proceed button. and the flashing process will begin. This may take several minutes and then the MP device will restart.

After the MP device has restarted and the WiFi led has started to flash, allow three minutes for the flashing process to complete. After that you should be able to connect to the MP device with web browser or telnet on the default LAN or Fallback IP addresses.

You may also use the IVR *C-O-N-F* (2663) command to change the MP device address to work on your LAN.



Installing with the *sysupgrade* Utility

To install with the *sysupgrade* utility on the MP device, it is necessary to copy the required *.img* file to the MP using the *scp* command from a *ssh* session on your PC.

A new MP device will only provide access via telnet until the root account password has been set, after which *telnet* will be disabled and *ssh* will be available.

If you are using a new MP it will operate with IP addresses of 10.130.1.20 (LAN) and 172.31.255.254 (Fallback). To use one of these addresses, configure your PC Ethernet networking profile with a static address to be able to access either of these addresses, and connect directly with an Ethernet cable to the MP device.

For example, to use the MP Fallback IP address, set the PC network profile to:

IP: 172.31.255.253 Netmask: 255.255.255.252

Alternatively you may set the MP device address to work on your LAN. Connect a telephone to the MP and dial the IVR command **C-O-N-F** (2663) and follow the prompts to set the IP number to one that lies in your normal LAN address range and is not already in use. The device will then reboot. Connect the MP device to an Ethernet port on your LAN and it will be accessible by any PC on the LAN.

To set the password, connect to the MP using *telnet*.

Once connected with telnet, execute the *passwd* command and enter the new password. You will be required to enter the password twice to check its accuracy. Once the password has been set, exit from the *telnet* session and reconnect using *ssh*.

From another terminal session on your PC, transfer the required *.img* file to the MP using the *scp* command e.g

```
scp ./openwrt-atheros-root-rv287.img root@172.31.255.254:/tmp
```

This will place the file in the */tmp* directory on the MP device. Note that the contents of */tmp* are stored in volatile RAM and thus will be lost on a system restart.

From the *ssh* session install the firmware with the command:

```
sysupgrade -nv ./openwrt-atheros-root-rv287.img
```

The flashing process will begin and may take several minutes, after which the MP device will restart.

After the MP device has restarted and the WiFi led has started to flash, allow three minutes for the flashing process to complete. After that you should be able to connect to the MP device with web browser or telnet on the default LAN or Fallback IP addresses.

You may also use the IVR **C-O-N-F** (2663) command to change the MP device address to work on your LAN.

4.2 Minimum Set-up

The Minimum Set-up process uses the telephone IVR facility to simply set a unique IP address for the *br-lan* bridge interface in order to allow telephone calls to the device using the IP address.

Even with this minimal configuration, the MP mesh network may be connected to a LAN and will provide WiFi and Ethernet connectivity for PCs and other devices to the LAN and Internet.

The default setting for the *br-lan* IP address when the device is flashed is 10.130.1.20 and you should change at least the last octet of the address in order to make the address unique on the mesh.

In a simple mesh arrangement, all MP devices on the mesh are assigned addresses in the same address range (ie only the last octet of the address is changed) so telephone calls can be made to all devices on the mesh with abbreviated dialling using just the last octet of the MP device's bridge IP address.

If you are intending to connect the mesh to a LAN, you may choose to assign addresses from the LAN address space to the MP devices so that they will appear as static IP devices on the LAN. In this case, just set the IP address of the MP device to the required IP address on the LAN. You will need to ensure that the address that has been assigned will not be used by any other device on the LAN in order to avoid IP conflicts.

Set the *br-lan* IP Address

Connect a telephone to the MP device and check that you have dial tone.

Use one of the methods below to set the device address.

Set Abbreviated Address:

- Pick up the telephone, check for dial tone and dial 2662
- Follow the voice prompts and enter the required number for the device as 1 – 3 digits e.g 21. This will set the last octet of the MP device IP address e.g. 10.130.1.21
- The number entered will be read back to you and the MP will reboot.

Set Full IP address:

- Pick up the telephone, check for dial tone and dial 2663 (C-O-N-F)
- Follow the voice prompts and enter the IP number in the form 10*130*1*21 (For an IP address of 10.130.1.21)
- The number entered will be read back to you and the MP will reboot.

After the device has rebooted, you should be able to make a call to the device using either the full IP number, or abbreviated dialling using just the last octet of the address.

Note: When the *br-lan* address is set using IVR, the device's *gateway* address will automatically be set to an address in the same subnet with the last octet set to **1** e.g 10.130.1.1

This is to ensure correct operation of Asterisk.

If you plan to connect the mesh devices to a LAN and you use this method to set up the MP to have an address in the LAN address space, then the MP will expect to find your LAN router at the *x.y.z.1* address. If your router has a different address, you may use the LUCI web interface to change the *gateway* and *dns* addresses accordingly.

Note: *This will be required if you wish to have the MP device itself to have access to the Internet, for example to support external VoIP calls.*

4.4 Set-up Using SECN Web Interface

Basic SECN Configuration

Mesh Potato Configuration

VillageTelco
SECN Mesh Potato Configuration

Click here for [LuCI Administration](#) . [Advanced SECN Configuration](#)

Network

IP Address Gateway Find Gateway

WiFi Access Point (WPA2 default)

Station ID Passphrase Channel

Asterisk

User Name Password
 SIP Host Dialout Code
 SIP Enable Status: **Not Registered**

Password

Enter Password Repeat Password

The **Basic SECN Configuration** screen may be accessed by pointing your web browser to the IP address of the MP device.

For a newly flashed device you may use the default IP address of 10.30.1.20 or the Fallback IP address of 172.31.255.253 To use either of these addresses you will need to configure networking on your PC to be able to access these subnets.

Alternatively you may wish to first set the IP address of the MP so that it appears on your LAN subnet by using the phone IVR menu as described in the previous section. If doing so, make sure that you assign an IP address that does not conflict with other devices on the network.

When accessing the configuration page, you will be prompted via a pop up dialog box on screen to login using the **root** account and password. On a newly flashed device the root account password will not have been set and should be left blank to login.

The **Basic SECN Configuration** screen allows you to set up just the key parameters for Network Address, Gateway, WiFi Access point, a SIP/VoIP phone service, and the password for the root account.

Links are provided at the top of this screen to allow access to the **Advanced SECN** and **LuCI** configuration screens if required.

Network Configuration

The network configuration parameters that can be set up are the **IP Address** for the MP device and the IP address for the **Gateway** (router) device on the local network which provides access to the Internet.

The **Find Gateway** button will attempt to locate the Gateway device by sending a DHCP Discover request on the network. If a device responds to the request, then the address of the responding device will be populated into the **Gateway** field on the screen.

A status message will be displayed at the bottom of the configuration form to show the result of the **Find Gateway** function.

If the gateway you wish to use is on a different IP address to the one found, simply enter the Gateway device address in the field and click on the Save button.

WiFi Access Point Configuration

The WiFi configuration allows you to set the **Station ID** (SSID), **Passphrase** and radio **Channel** for the MP device.

The **Station ID** must be comprised of alphanumeric characters (plus dash and underscore). This is the name of the WiFi Access-point that will be seen from a WiFi client device attempting to connect.

The **Passphrase** will be required to allow a client to connect if WiFi encryption is being used. The **Passphrase** must be comprised of alphanumeric characters (plus dash and underscore) and must be a minimum of eight characters in length.

Note that as this is the only security that prevents wireless access to your network, you should change the default password and make it suitably strong by using a combination of upper and lower case letters, and numbers.

By default the SECN firmware operates using WPA1-PSK encryption on the WiFi access point. You may change the encryption if required on the **Advanced** screen.

VoIP Configuration

The VoIP configuration allows you to set up a SIP/VoIP service to make calls beyond the local mesh if you wish. Typically this is via a commercial VoIP service provider that provides access to the standard telephone network.

Note that for this to work, the MP device must be correctly configured and operating on a network which provides Internet access for the MP through the specified gateway. The settings are used to update the `/etc/asterisk/sip.conf` file via the `potato.sip.conf` file.

When you establish an account with a SIP/VoIP provider, you will be given a **User Name** and **Password**, as well as the URL of the SP server on the Internet. Enter these details in the relevant fields on the screen.

The **Dialout Code** is used to distinguish between calls to be made on the local mesh, and those to be routed out to the SIP/VoIP provider. The specified digit is dialled before the required external number. The available digits are #, 0 and 9.

The **SIP Enable** checkbox allows you to enable or disable the external SIP service while keeping the saved settings.

After entering the required settings, click the **Save and Restart Asterisk** button. If the MP can successfully contact the SIP server and register, the registration status will be shown below the **Dialout** control.

Note that registration may take some time and the status may not show immediately. You can click the **Refresh** button to check the status.

Saving and Rebooting

The **Refresh** button will simply refresh the field values from saved values in memory and check the registration status of the SIP/VoIP service.

The **Save** button writes the various field values on the screen into memory, but does not change the operation of the MP device.

The **Save and Restart Asterisk** button will save all field values and restart the Asterisk telephony subsystem. This usually takes about 10 seconds to complete, but may take longer if Internet access is not configured correctly.

The **Save and Reboot** button will save the field values and restart the MP device using the newly saved values. Note that **a system reboot is required** to effect changes to the network settings and will take two minutes to complete.

Advanced SECN Configuration

Mesh Potato Configuration

SECN Mesh Potato Configuration

Click here for [LuCI Administration](#) · [Basic SECN Configuration](#) · [SECN Wireless Status](#)

Network

IP Address	<input type="text" value="192.168.1.21"/>	Gateway	<input type="text" value="192.168.1.254"/>
DNS	<input type="text" value="8.8.8.8"/>	Netmask	<input type="text" value="255.255.255.0"/>

WiFi Access Point

SSID	<input type="text" value="Mesh-Potato-AP"/>	Encryption	<input type="button" value="WPA1"/>
Passphrase	<input type="text" value="potato-potato"/>	Channel	<input type="button" value="1"/>

Mesh Wireless Interface

IP Address	<input type="text" value="10.10.1.20"/>	Netmask	<input type="text" value="255.255.255.0"/>
SSID	<input type="text" value="potato"/>	BSSID	<input type="text" value="01:CA:FF:EE:BA:BE"/>
Tx Power (10 - 20)	<input type="text" value="17"/>	Country Code	<input type="text" value="276"/>

VoIP Configuration

SIP Registrar	<input type="text" value="sip.myhost.com"/>	User Name	<input type="text" value="myusername"/>
SIP Host	<input type="text" value="sip.myhost.com"/>	Password	<input type="text" value="mysecret"/>
Outbound Proxy	<input type="text" value="sip.myhost.com"/>	From Domain	<input type="text" value="mysecret"/>
NAT External IP	<input type="text" value="0.0.0.0"/>	Enable Asterisk NAT	<input type="checkbox"/>
Dialout Code	<input type="button" value="#"/>	SIP Enable	<input type="checkbox"/>
		Register	<input type="checkbox"/>

Status: **Not Registered**

Codec1	<input type="button" value="gsm"/>	Codec2	<input type="button" value="ulaw"/>	Codec3	<input type="button" value="alaw"/>
--------	------------------------------------	--------	-------------------------------------	--------	-------------------------------------

DHCP Server

Enable DHCP Server

Starting IP	<input type="text" value="10.130.1.200"/>	Ending IP	<input type="text" value="10.130.1.240"/>
Lease Term (secs)	<input type="text" value="7200"/>	Max Leases	<input type="text" value="40"/>
DNS	<input type="text" value="8.8.8.8"/>	Domain Name	<input type="text" value="lan"/>
Subnet Mask	<input type="text" value="255.255.255.0"/>	Router	<input type="text" value="10.130.1.1"/>

The **Advanced SECN Configuration** screen may be accessed by clicking on the link at the top of the **Basic SECN Configuration** page.

This screen allows you to set up just the key parameters for Network, WiFi, a SIP/VoIP phone service, and DHCP server.

Links are provided at the top of this screen to allow access to the **Basic SECN** and **LuCI** configuration screens if required.

Network Configuration

The network configuration parameters that can be set up are the **IP Address** and **Netmask** for the MP device, the IP address for the **Gateway** (router) device on the local network, which provides access to the Internet, and the IP address of the **DNS** server to be used for name resolution.

WiFi Access Point Configuration

The WiFi configuration allows you to set the **Station ID** (SSID), **Passphrase**, **Encryption** and radio **Channel** for the MP device.

The **Station ID** must be comprised of alphanumeric characters, plus dash and underscore. This is the name of the WiFi Access-point that will be seen from a client device attempting to connect.

The **Passphrase** will be required to allow a client to connect if WiFi encryption is being used. The passphrase must be comprised of alphanumeric characters (plus dash and underscore) and must be a minimum of eight characters in length.

Note that as this is the only security that controls access to your network, you should change the default password and make it suitably strong by using a combination of upper and lower case letters, and numbers.

The **Encryption** control allows you to select from WPA1-PSK, WPA2-AES, WEP or Open encryption on the WiFi Access-point.

Mesh Wireless Interface Configuration

The Mesh Wireless configuration allows you to set a number of parameters for the mesh **ath0** interface including: IP Address, Netmask, SSID, BSSID, Transmit Power, and Country Code. These values are written into the configuration files **/etc/config/network** and **/etc/config/wireless**.

The **ath0** interface used for the mesh wireless protocol has an **IP Address** and **Netmask**. These are set to default values of 10.10.1.20 and 255.255.255.0 and normally do not need to be altered. These settings are **not** used for the mesh protocol and so all MP devices on the mesh may remain on the default IP address.

The **ath0** address can be used to access the MP device for maintenance in the same way as the Network Address or the Fallback Address described previously. If it is intended to use this address for maintenance access, it should be set to a unique value to avoid any potential ip address conflict.

The **SSID and BSSID** parameters set the station identification for the MP on the mesh and should be set the same for all devices in a mesh cell. These parameters can be used to set up separate mesh cells if required.

The **Tx Power** parameter may be used to adjust the power of the MP radio transmitter. It is set by default to the maximum value of 17. Normally this should not need to be adjusted but doing so may be useful in certain circumstances such as testing.

The **Country Code** is set to a default value of 276 which corresponds to Germany. This parameter sets the available channels which may be used and the default setting is appropriate for most jurisdictions. Care should be taken when changing this value to ensure that the value chosen is appropriate to the local situation avoid possible channel conflicts with other radio services.

VoIP Configuration

The VoIP configuration allows you to set up a SIP/VoIP service to make calls beyond the local mesh if you wish. Typically this is via a commercial VoIP service provider that provides access to the standard telephone network.

Note that for this to work, the MP device must be correctly configured and operating on a network which provides Internet access for the MP through the specified gateway.

The settings are used to update the `/etc/asterisk/sip.conf` file via the included `potato.sip.conf` file.

When you establish an account with a SIP/VoIP provider, you will be given a **User Name** and **Password**, as well as the URL of the SP server on the Internet. Enter these details in the relevant fields on the screen.

The **Dialout Code** is used to distinguish between calls to be made on the local mesh, and those to be routed out to the SIP/VoIP provider. The specified digit is dialled before the required external number. The available digits are #, 0 and 9.

The **SIP Enable** checkbox allows you to enable or disable the external SIP service while keeping the saved settings.

The **Nat Enable** checkbox may be used to enable Asterisk use behind a NAT firewall. Normally this is not required for a LAN behind a simple router/NAT firewall providing Internet access, but will be required for example if the MP is behind a second NAT firewall. If used, the **External NAT IP** field should be set to the upstream network IP address of the NAT router to which the MP is connected.

The **Codec** settings may be used to control the Codecs available to be used for calls. Normally this will not need to be changed, however some SIP/VoIP providers do require specific codecs to be used, in particular for calls outside their immediate domain.

After entering the required settings, you may click the **Save and Restart Asterisk** button. If the MP can successfully contact the SIP server and register, the registration status will be shown in a text line below the **Dialout** control.

Note that registration may take some time and the registered status may not show up when the screen is first refreshed. You can click the **Refresh** button to check the status.

DHCP Server Configuration

The DHCP configuration allows you to set up a DHCP server to operate on the MP device. This may be used, for example, to ensure that devices attaching to the mesh network are able to obtain an IP address via DHCP in the event that there is no service available from a gateway device, perhaps due to loss of the uplink to a remote device.

Note: Care must be taken in setting up the configuration of the DHCP server to ensure that there is no conflict between multiple DHCP servers that are visible to devices attached to the network.

The DHCP server provides IP address leases and a range of network information to clients in response to a DHCP Discovery request. The settings for the DHCP server that can be configured from the MP device web interface are outlined below.

The **Enable DHCP Server** checkbox allows the server in the MP device to operate when it is checked. By default the DHCP server is not enabled.

The **Starting** and **Ending IP** fields set the range of addresses that will be handed out by the DHCP server. Care must be taken to ensure that this range does not overlap the range of any other DHCP server on the network.

Lease Term sets the time period in seconds that IP address leases are valid.

Max Leases sets the maximum number of concurrent leases that will be handed out.

DNS defines the Domain Name Server IP address that will be handed out to clients as part of the DHCP protocol.

Domain Name sets the network name that will be handed out to clients as part of the DHCP protocol.

Subnet Mask sets the network mask that will be handed out to clients as part of the DHCP protocol.

Router sets the IP address of the network gateway that will be handed out to clients as part of the DHCP protocol.

Saving and Rebooting

The **Refresh** button will simply refresh the field values from saved values in memory and check the registration status of the SIP/VoIP service.

The **Save** button writes the various field values on the screen into memory, but does not change the operation of the MP device.

The **Save and Restart Asterisk** button will save all field values and restart the Asterisk telephony subsystem. This usually takes about 10 seconds to complete, but may take longer if Internet access is not configured correctly.

The **Save and Reboot** button will save the field values and restart the MP device using the newly saved values. Note that **a system reboot is required** to effect changes to the network settings and will take two minutes to complete.

The **Restore Defaults** button will reset all the configuration settings to the default values of a newly flashed device.

4.4 Set-up using OpenWRT Web Interface

The OpenWRT web interface of the MP device allows you to set some of the SECN system parameters including the password for the *root* account, the *br-lan* bridge IP address, and the *ath0* mesh interface address.

In addition you may use the LUCI interface to add software packages to the MP device, and other facilities supported in the interface.

If you are using a new MP it will operate with IP addresses of 10.130.1.20 (LAN) and 172.31.255.254 (Fallback). To use one of these addresses, configure your PC Ethernet networking profile with a static address to be able to access either of these addresses, (eg to use the MP Fallback IP address, set the PC to IP: 172.31.255.253 Netmask: 255.255.255.252) and connect directly with an Ethernet cable to the MP device.

Alternatively you may set the MP device address to work on your LAN. Connect a telephone to the MP and dial the IVR command *C-O-N-F* (2663) and follow the prompts to set the IP number to one that lies in your normal LAN address range and is not already in use. The device will then reboot. Connect the MP device to an Ethernet port on your LAN and it will be accessible by any PC on the LAN.

TBD ***** Point your browser to the MP device IP address. This will display the OpenWRT LUCI login screen. After flashing the MP device there will be no password set for the *root* account, so you can log in with the password field blank.



Set the root Password

Select *System / Admin Password* from the menu and enter the new password.

Then click on the *Save & Apply* button at the lower right of the page.

Once the password has been set and the change committed, future logins will require the password to be entered. In addition, *telnet* connections will be disabled and *ssh* sessions will be required for terminal session connections.

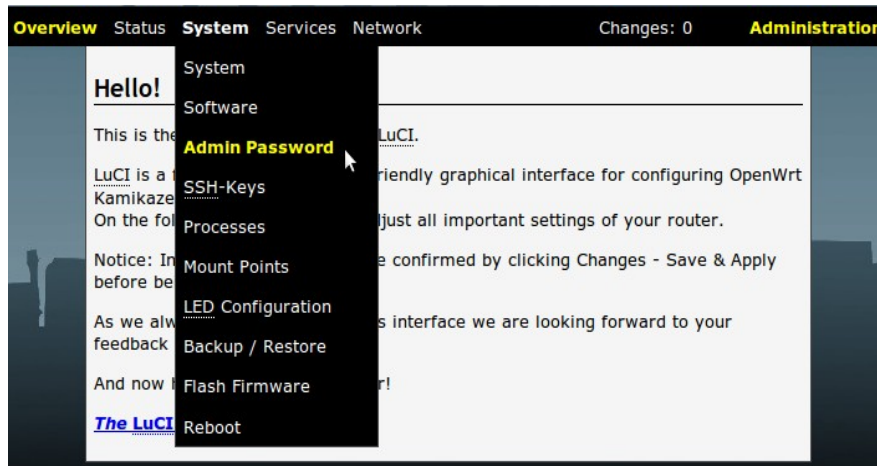

Set the *br-lan* Bridge IP Address

This step sets the unique IP address for the *br-lan* bridge interface which is used for making telephone calls to the MP device, and may be used to access the MP device for maintenance.

The default setting for this IP address when the device is flashed is 10.130.1.20 and you should change at least the last octet of the address in order to make the address unique on the mesh.

In a simple mesh arrangement, all MP devices on the mesh are assigned addresses in the same address range (ie only the last octet of the address is changed) so telephone calls can be made to all devices on the mesh with abbreviated dialling using just the last octet of the MP device's bridge IP address.

If you are intending to connect the mesh to a LAN, you may choose to assign addresses from the LAN address space to the MP devices so that they will appear as static IP devices on the LAN. In this case, just set the IPv4 address field to the required IP address. You will need to ensure that the address that has been assigned will not be used by any other device on the LAN in order to avoid IP conflicts.

From the LUCI web interface menu select *Network / Interfaces / LAN*

Interface : *eth0 bat0 ath1*

Set the required IP address for the device eg :

IPv4-Address: *10.130.1.22*

Click on the *Save* button at the bottom right of the screen.

This will just save the change but not apply it until the *Save&Apply* button is selected. This allows you to make other network configuration changes before the changes are committed and the device restarts.

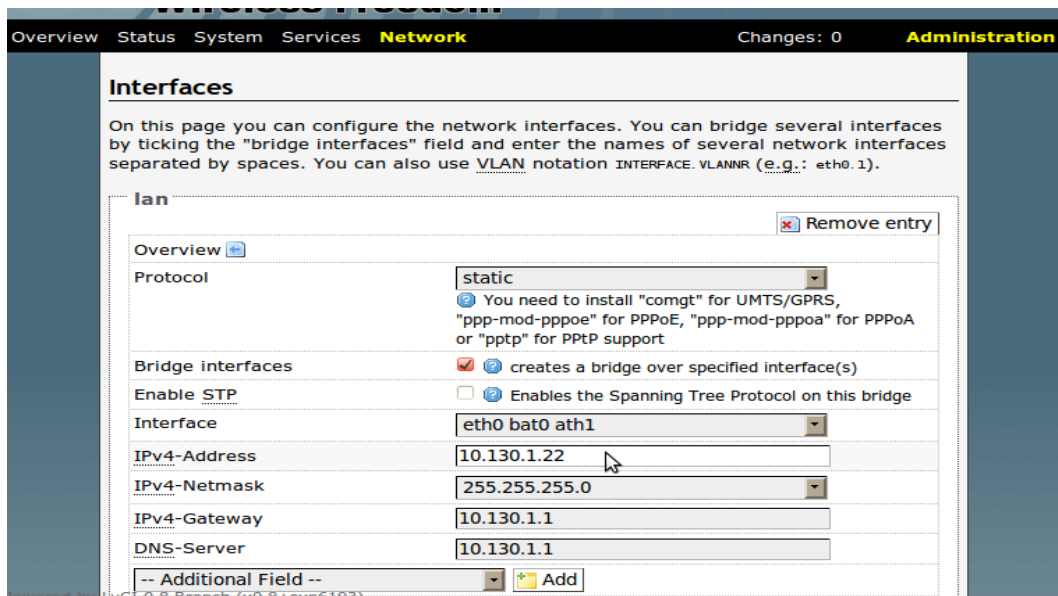

Set the *ath0* IP Address

This step sets a unique IP address for the *ath0* mesh interface. Changing this address is optional – the device will perform in the mesh just as well without any change.

One reason you might want to change this address is to allow connection to the device for maintenance purposes at a unique address with a PC able to operate in *ah-demo* WiFi mode. Conversely, leaving all the *ath0* addresses the same provides a known address that will work on any device.

The default setting for this IP address when the device is flashed is 10.10.1.20 and you may choose to change just the last octet of the address in order to make the address unique on the mesh, or you may choose to change the whole address range.

If you are changing the last octet of the address, it is a useful convention to make it the same as the bridge address.

When you have made the required changes, click *Save* at the lower right of the page.

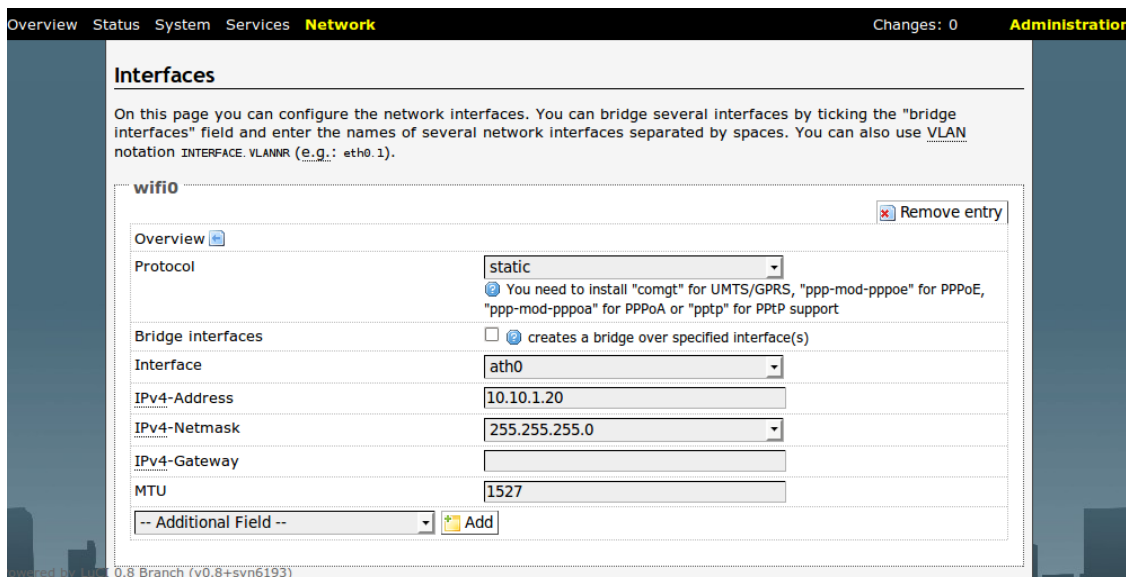

Committing Network Changes

When **all** required network changes have been made, click *Save&Apply* to commit the changes.

Making changes to the network settings will generally mean that you lose the connection to the device, and the browser screen will freeze as a result.

At this point it is preferable to restart the device with a power down cycle to ensure that it resumes operation in a known state.

Managing Software Packages

The *System / Software* menu allows you to add software packages from a repository.

4.5 Advanced Set-up

Advanced Set-up utilises access to the Linux operating system on the MP device and permits full access to all configuration facilities as well as adding and configuring additional software packages.

Access to the MP device for Advanced Set-up is by means of a command line from a *telnet* or *ssh* terminal session.

Connecting to the MP

When first flashed with new firmware, the MP device supports a *telnet* connection.

This facility is disabled as soon as the *root* password is set.

Connect to the MP via *telnet* using the MP device's Fallback address: 172.31.255.254

Set PC network to: IP: 172.31.255.253 Netmask: 255.255.255.252

Set the *root* password with the *passwd* command and exit.

Connect to the MP via *ssh* and login.

Setting the MP Network Addresses

Setting the *br-lan* Bridge IP Address

Set the unique IP address for the *br-lan* interface of the MP device by using the *uci* command, or by directly editing the network configuration file.

From the command line:

```
uci set network.br-lan.ipaddr=103.130.1.xxx (Where xxx is unique to each MP)
uci commit network
```

Editing the */etc/config/network* file:

```
config 'interface' 'lan'
    option 'type' 'bridge'
    option 'ifname' 'eth0 bat0 ath1'
    option 'proto' 'static'
    option 'netmask' '255.255.255.0'
    option 'gateway' '10.130.1.1'
    option 'dns' '10.130.1.1'
    option 'ipaddr' '10.130.1.xxx' (Where xxx is unique to each MP)
```

Setting the *ath0* IP Address

You may wish to change the *ath0* IP address, however this is not required for basic mesh operation.

From the command line:

```
uci set network.wifi0.ipaddr=10.130.1.xxx    (Where xxx is unique to each MP)
uci commit network
```

Editing the */etc/config/network* file:

```
config 'interface' 'wifi0'
    option 'ifname' 'ath0'
    option 'proto' 'static'
    option 'ipaddr' '10.10.1.xxx'
    option 'netmask' '255.255.255.0'
    option 'mtu' '1527'
```

Set the Access Point SSID and WPA Passphrase

Edit the */etc/hostapd.conf* file:

```
interface=ath1
bridge=br-lan
driver=madwifi

# Edit SSID as required
ssid=Mesh-Potato-AP

country_code=DE
hw_mode=g
wpa=1

# Edit WPA Passphrase as required
wpa_passphrase=potato-potato

wpa_key_mgmt=WPA-PSK
macaddr_acl=0
ctrl_interface=/var/run/hostapd
```

Modifying Asterisk Operation

Setting up External SIP / VoIP Operation

To add external VoIP support, changes are required to an Asterisk configuration include file, *potato.sip.conf*, on the individual MP where the access is required in order to specify the details of the required SIP / VoIP service account.

Sip / VoIP Account Details

In the */etc/asterisk/potato.sip.conf* file make the following changes:

a) Edit the following line to register with the VoIP provider:

```
; Register to VoIP Provider
register => myusername:mysecret@sip.mysipprovider.com_
```

b) Edit the *[sipaccount]* section to define the account details:

```
[sipaccount]
host=sip.mysipprovider.com           (typical address for SIP / VoIP host server)
secret=mysecret
username=myusername
fromuser=myusername
insecure=port,invite
type=friend
disallow=all
allow=gsm,ulaw,alaw
dtmfmod=rfc2833
qualify=yes
canreinvite=no
nat=yes
context=default
```

Note: Ensure that the edited lines are un-commented by removing leading *semicolon* characters.

Dial Plan for SIP / VoIP

The dial plan for external SIP / VoIP operation is defined in the configuration include file */etc/asterisk/potato.extensions.conf* as follows:

```
; Send incoming calls to the MP
exten => s,1,Dial(MP/1)
; Make outgoing calls using [sipaccount] details
; Dial # for access, and then required number string
exten => _#,1,Dial(SIP/${EXTEN:1}@sipaccount,120,r)
```

This simple default dial plan requires a # digit to be dialled at the start of the phone number to be sent to the SIP / VoIP service i.e. '*dial # for an outside line*'. The # digit is stripped off before the number is sent. This character may be changed to suit your local requirements.

5. Overview of SECN Operation

This configuration uses Batman-advanced for the mesh rather than Batman as used in earlier firmware versions. Batman-advanced uses a different mesh protocol to batman and so the two won't interoperate on the same mesh.

The MP device provides two physical network interfaces, Ethernet cable and wireless, which are configured as follows:

- The *eth0* interface operates on the MP Ethernet cable connection.
- Two wireless interfaces, *ath0* and *ath1*, are set up on the wireless interface *wifi0*.
- Batman-adv is configured to run on the *ath0* interface using the *batctl* command and generates the *bat0* interface.
- The second wireless interface, *ath1*, is set up to operate as a WiFi access point using the *iwconfig* command.
- The *bat0*, *ath1* and *eth0* interfaces are bridged (*br-lan*) together in each MP and assigned a static IP address, and thus, due to the operation of the mesh via *bat0*, all the *ath1* and *eth0* interfaces of all the MPs in the mesh are similarly bridged.
- The default IP address range used for the *br-lan* interface is 10.130.1.xxx

The mesh will operate in a stand-alone configuration, simply connecting attached devices together and providing telephony between devices. Alternatively the mesh may be interconnected to a LAN to provide access to additional resources, including internet connectivity.

If one of the MP devices is connected via Ethernet cable to a LAN router, then all WiFi and Ethernet interfaces connected to the meshed MPs will have access to the LAN resources.

If there is a DHCP server running on the LAN (eg in the router) then devices configured as DHCP clients connected to the MPs will acquire an IP address just as if they were connected directly to the LAN.

Note that there is no DHCP server running in a stand-alone mesh arrangement by default, and so in this case, attached devices would need to be statically configured for their IP address.

5.1 IP Address Range for MPs

It should be noted that the IP address used for the *br-lan* bridge in the MP devices needs to be configured during setup, and **may** or **may not** be made to lie in the IP address space used on the LAN to which the mesh may be connected. Operation is essentially the same in both cases, but care must be taken to manage the address space in the former case.

IP addresses assigned to MP devices are static. If the IP addresses used for the MP devices lie in the same address space as the LAN, then the DHCP server and other devices on the LAN must be appropriately configured so that the addresses assigned to the MP devices are left free in order to avoid IP address conflicts. In this arrangement, the MP devices will appear on the LAN just as any other device with a static IP address, and they may be accessed for management via browser or ssh terminal session.

Conversely, if the IP address range used for the MP devices is separate to that used on the LAN, the MP devices will not appear on the LAN and there is no need to reserve the address space. In order

to access the MPs for management in this configuration, it is necessary to configure a PC with a static address in the same range as the MPs, and attach via Ethernet cable or WiFi.

The default IP address assigned to the *br-lan* interface in the MPs is 10.130.1.20 which is unlikely to conflict with the default address range of commodity routers.

If it is desired to have the MPs appear on the LAN, the *br-lan* IP address should be assigned accordingly during set up.

The address assigned to the *br-lan* interface for each MP must be changed to be unique, so that each device can provide a separate telephone number. This IP address assignment may be made by a number of methods including telephone IVR, web interface or manipulation of the */etc/config/network* file.

5.2 Batman-Advanced Operation

Batman-advanced is a "OSI layer 2" routing protocol which is implemented as a kernel module in the Linux kernel. Since Linux 2.6.38 batman-advanced is an official part of Linux.

When you assign at least one active physical network interface to batman-advanced, it will create the virtual *bat0* interface. In the SECN firmware *ath0* is assigned to the batman-advanced kernel module. *ath0* is the wireless interface operating in multipoint-to-multipoint mode (ad-hoc).

Because batman-advanced operates entirely on MAC layer (OSI layer 2), *ath0* doesn't need any Layer 3 configuration. Only its Layer 2 MAC address is required. The MAC address is configured during production, so we don't need to configure it. All we need to do is make sure to switch *ath0* on. To sum it up: *ath0* is the link-local transport interface for the batman-advanced mesh.

Batman-adv itself bridges all *bat0* interfaces in all the mesh devices to a big, smart, virtual switch. This means that all *bat0* interfaces in the mesh are link-local - even if they are multiple wireless hops away.

Despite being virtual, *bat0* acts like a real, physical, network interface connected to a big switch. As such you can run all kinds of network protocols on it, like IPv4, IPv6, ARP, Zeroconf (yes, you can run mDNS on *bat0*!), IPX – or whatever protocol that can communicate over a network interface that is connected link local (which means directly connected, like a straight Ethernet cable connected between two computers, or a bunch of computers connected to a switch).

In the SECN firmware the *bat0* interface itself is again assigned (or rather enslaved) to a bridge in each machine. *bat0* is part of the bridge named *br-lan*, together with *ath1* and *eth0*.

eth0 is the LAN port of the MP. *ath1* is a access-point interface, operating as a master in WiFi infrastructure mode. (As opposed to a infrastructure client, like laptops or smartphones with a WiFi interface).

Hence **all** *eth0* and *ath1* interfaces in **all** devices running the SECN firmware are part of **one** big wireless bridge. The *ath0* interface does the low level work to carry the traffic link-locally from hop to hop and batman-advanced takes care about the routes that the MAC packets have to take.

Note: It is not possible to add IP settings to an interface which is encapsulated in a bridge - you can only assign IP settings to the bridge interface itself. *eth0* is part of the bridge *br-lan*, together with *ath1*, *bat0* (the batman-advanced virtual interface, which is routed by the mesh routing protocol using MAC addresses). Hence you can not assign any IP settings to *eth0*, *ath1* or *bat0* - only to *br-lan*.

BATCTL Command

The following description is taken from the man page published by OpenMesh.org at:
<http://downloads.open-mesh.org/batman/manpages/batctl.8.html>

Syntax *batctl* [*batctl-options*] *command* [*command-options*]

This command offers a convenient way to configure the batman-adv kernel module as well as displaying debug information such as originator tables, translation tables and the debug log. In combination with a bat-hosts file batctl allows the use of host names instead of MAC addresses.

B.A.T.M.A.N. advanced operates on layer 2. Thus all hosts participating in the virtual switched network are transparently connected together for all protocols above Layer 2. Therefore the common diagnosis tools do not work as expected. To overcome these problems batctl contains the commands **ping**, **traceroute**, **tcpdump** which provide similar functionality to the normal **ping(1)**, **traceroute(1)**, **tcpdump(1)** commands, but modified to Layer 2 behaviour or using the B.A.T.M.A.N. advanced protocol.

Commands of particular interest include the following:

originators|o [-w [*interval*]][-n][-t]

Once started batctl will display the list of announced gateways in the network. Use the "-w" option to let batctl refresh the list every second or add a number to let it refresh at a custom interval in seconds (with optional decimal places). If "-n" is given batctl will not replace the MAC addresses with bat-host names in the output. The "-t" option filters all originators that have not been seen for the specified amount of seconds (with optional decimal places) from the output.

gw_mode|gw [off|client|server] [sel_class|bandwidth]

If no parameter is given the current gateway mode is displayed otherwise the parameter is used to set the gateway mode. The second (optional) argument specifies the selection class (if 'client' was the first argument) or the gateway bandwidth (if 'server' was the first argument). If the node is a server this parameter is used to inform other nodes in the network about this node's internet connection bandwidth. Just enter any number (optionally followed by "kbit" or "mbit") and the batman-adv module will guess your appropriate gateway class. Use "/" to separate the down- and upload rates. You can omit the upload rate and the module will assume an upload of download / 5.

default: 2000 -> gateway class 20

examples: 5000 -> gateway class 49
5000kbit
5mbit
5mbit/1024
5mbit/1024kbit
5mbit/1mbit

If the node is a gateway client the parameter will decide which criteria to consider when the batman-adv module has to choose between different internet connections announced by the aforementioned servers.

bat-hosts

This file is similar to the */etc/hosts file*. You can write one MAC address and one host name per line. batctl will search for bat-hosts in /etc, your home directory and the current directory. The found data is used to match MAC address to your provided host name or replace MAC addresses in debug output and logs. Host names are much easier to remember than MAC addresses.

Batman-adv and Gateways

Amongst performance improvements and faster handover of clients, the batman-adv package for the MP now supports configuring advanced batman-adv gateway and gateway client parameters via UCI.

Note: You only need this if you want to use more than one gateway in the mesh. In this case set the gateway MPs mode to Server and the other MPs mode to Client

An example how to configure a MP as batman-adv gateway:

```
root@MP-2:/# uci set batman-adv.bat0.gw_mode=server
root@MP-2:/# uci set batman-adv.bat0.gw_bandwidth=384kbit/128kbit
root@MP-2:/# uci commit
root@MP-2:/# /etc/init.d/batman-adv restart
```

Setting the downlink/uplink speed of the gateway like in this example is optional, if you want to override the default value.

For more info check out <http://downloads.open-mesh.org/batman/manpages/batctl.8.html>

An example how to configure a MP as batman-adv gateway client:

```
root@MP-2:/# uci set batman-adv.bat0.gw_mode=client
root@MP-2:/# uci commit
root@MP-2:/# /etc/init.d/batman-adv restart
```

By default the clients will connect to the gateway with the 'best' access (qualified by the TQ route metric, which measures route quality) in the mesh. As long as no other gateway has a TQ route metric which is more than 20 counts better than the currently selected gateway, the clients will stick to the current gateway. If another gateway is more than 20 TQ counts better, the clients will switch the selected gateway. You can, of course, tweak this threshold.

If you want to do some fancy - experimental - setup like dynamically changing the announced gateway bandwidth, in order to balance the load of the gateways, you can change the clients gateway selection algorithm.

Example:

```
uci set batman-adv.bat0.gw_mode=client 1
uci commit
/etc/init.d/batman-adv restart
```

This setting will configure the clients to select the gateway in order to find the best compromise of TQ route metric and announced gateway speed. A 100Mbit/100Mbit gateway is useless if the TQ route metric is small.

Again:

For more detailed info check out the batctl man page at open-mesh.net.

5.3 Telephony Operation

Overview

MP devices provide an RJ11 port to which a telephone may be connected and each MP device runs a copy of the Asterisk application to provide the telephony facilities. Asterisk allows phone calls to be made between devices by means of Voice over IP (VoIP) and Session Initiated Protocol (SIP).

Interactive Voice Response (IVR) Commands

The MP Asterisk configuration includes several telephone extension numbers that allow interaction with the device using Interactive Voice Response (IVR) system. These numbers include:

2661	Read out the <i>ath0</i> mesh wireless interface IP address
2664	Read out the <i>br-lan, eth0, ath1 network</i> interface IP address
7774	RSSI Read out the <i>rss</i> i signal strength
2426	CHAN Set wireless channel
2662	Set the unique <i>network</i> IP address of the MP device – Last octet.
2663	CONF Set the unique <i>network</i> IP address of the MP device – Full IP.
4283	GATE Set the IP address of the network gateway used by the MP device.
6749	MPGW Set the mesh batman-adv gateway mode of the MP device.
7277	PASS Set root password of the MP device.
7466	PINN Set IVR PIN number
9434	WIFI Set WiFi passphrase
73738	RESET Restore factory default configuration settings
9999	Restart Asterisk

IVR Command Summary

Commands which change the system configuration require the entry of the IVR PIN number for security. The initial IVR PIN number is set to **1234** This should be changed before deployment.

Commands which have a variable number of input digits will wait for a timeout period after the last digit has been input to complete the command. The command may be terminated immediately by keying in the **#** digit after the last command digit has been entered.

Commands which require the MP device to be restarted to take effect (e.g. network settings) will include a message advising this fact.

The **2661** and **2662** commands simply read out the IP addresses used by the MP device on the mesh and on the wifi and ethernet network carried on the mesh, respectively.

The **RSSI** command **7774** will read out the signal strength of neighbouring MP devices. This is intended to assist with adjusting the MP device's location and orientation for best signal from its neighbours on the mesh.

If the mesh has *batman-adv* gateways set up the RSSI command will list the signal strength values for each neighbour which is selected as a next hop towards a gateway as follows:

Gateway nexthop ... 1 ... 34, Gateway nexthop ... 2 ... 22,

If you want to enable batman-adv gateways on the fly, switch them on with the command:

batctl gw server

In the absence of gateways the RSSI command will read out the signal strength values for all neighbours as follows:

Neighbour 1....36, Neighbour 2.....42, Neighbour 3.....28

Other useful terminal commands for monitoring signal strength are:

wlanconfig ath0 list Lists signal data for nearby devices on the mesh.

wlanconfig ath1 list Lists signal data for devices attached to the MP's WiFi Access Point.

batctl o Lists nearby devices on the mesh.

The **CHAN** command **2426** sets the wireless channel used for the mesh and wifi interfaces.

The **CONF** command **2663** is used to set the unique network address of the MP device using the full IP number. The **2662** command changes only the last octet of the IP address. If the MP device is attached to a network and the specified IP address is already in use, the commands will fail.

The **GATE** command **4283** sets the IP address of the network gateway that the MP can use to access IP addresses beyond the local network, such as Internet addresses.

The **MPGW** command **6749** sets the *batman-adv* gateway mode of the MP. This setting is used to assist with efficient routing of traffic on the mesh. If more than one MP on the mesh is connected to a gateway, these MP devices should have their gateway mode set to **Server**, with other MP devices set to **Client**. If only one MP device on the mesh is connected to a gateway then it is useful to announce this device by setting its gateway mode to **Server**.

The **PASS** command **7277** sets the root account password on the MP device as a numeric string. The password should be set before the device is deployed in the field in order to disable insecure telnet and enable ssh for access to the device.

The **PINN** command **7466** sets the four digit IVR PIN number, which should be changed from the default 1234 before the device is deployed in the field.

The **WIFI** command **9434** sets the encryption passphrase used for secure wifi access as a numeric string. A minimum of eight characters is required and the passphrase should be changed from the default before field deployment.

The **RESET** command **73738** restores the device to the original factory default settings.

The **Restart Asterisk** command **9999** can be useful to ensure that the telephony sub-system is initiated correctly after the mesh network starts up and Internet access becomes available for registering external SIP providers. Restart time for Asterisk is a few seconds, after which dial tone will be available.

Asterisk Operation

The operation of Asterisk is controlled to a number of configuration files, two of which are of particular interest for MP devices - */etc/asterisk/extensions.conf* and */etc/asterisk/sip.conf*. The *extensions.conf* file sets up the dial plan while the *sip.conf* file defines the channels to be used for making calls.

Operation of Asterisk can be monitored from the MP command line by executing the commands:

```
# asterisk -r
# asterisk -vvvvvrddd  Launches with Verbose Lev 5 and Core Debug Lev 3.
```

Useful commands in the Asterisk shell include:

CLI> exit	Return to the command shell
CLI> help	Displays a list of available commands
CLI> core set verbose 5	Set verbose level to 5
CLI> sip reload	Reload sip.conf configuration
CLI> dialplan reload	Reload extensions.conf dialplan
CLI> show dialplan default	Display current dial plan
CLI> sip show registry	Display sip registrations

Making Calls to MP Devices

To dial an MP device using the full IP address, dial the IP number substituting the * character for the dots between octets in the address. To dial an MP with address 10.130.1.21, dial

```
10*130*1*21
```

The SECN firmware includes a facility for making on mesh calls using abbreviated dialling by using just the last octet of the MP device's IP address. When an abbreviated number dial string is detected, the full IP address is generated by pre-pending the rest of the address.

The IP address used for on mesh abbreviated dialling is set up during the start up process by the script */bin/generate-extension.sh*, using the MP device's own *br-lan* IP address as reference.

To dial an MP device using abbreviated dialling, simply dial the last octet of the unique IP number assigned to the required MP. This can be dialled as 1, 2 or 3 digits, and may include leading 0 eg

5, 05, 005	(device address 10.130.1.5)
25, 025	(device address 10.130.1.25)
105	(device address 10.130.1.105)

Debugging Asterisk Operation

Asterisk provides a comprehensive interactive console mode to allow you to monitor its operation.

If Asterisk is already running, invoke the console mode with the command:

```
# asterisk -vvvvvrddd
```

This will run the console with Verbosity set to Level 5, and Core Debug set to level 3, which generally gives good visibility of what is happening. It does not interfere with the operation of Asterisk.

An extensive set of commands is available from the Asterisk CLI command line.

To see a list of these commands type: *help*

To exit the console mode, type: *exit*

If Asterisk is not already running, you can start it up with console mode running with the command:

```
# asterisk -vvvvvrgcddd
```

This can be useful for monitoring the start-up behaviour of Asterisk.

Asterisk and Network Settings

Asterisk has some very particular requirements around network settings, specifically:

Network DNS Address

Firstly, during Asterisk start-up, it will test for the presence of a ping response from the DNS *nameserver* address specified in the */etc/resolv.conf* file. It may wait for a period of many seconds for a response, which will affect the start up delay for the whole device. This delay can be seen in the Asterisk console. In the MP device firmware, the Asterisk start-up script temporarily uses the local host address for the DNS setting to ensure fast start-up.

Secondly, for external SIP / VoIP operation, Asterisk will use the *nameserver* value in */etc/resolv.conf* to resolve the URL of the SIP / VoIP host server on the internet. If there is no valid DNS service operating on this address, or the DNS address is not accessible from the MP device, Asterisk will fail to register the SIP / VoIP service and will complain of a *DNS error* in the Asterisk interactive console output.

Network Gateway Address

Asterisk requires that the network *gateway* address specified in */etc/config/network* be in the same IP subnet range as the MP's IP address, *even if there is no device actually present at this address*.

If the *gateway* address is not in the correct subnet, Asterisk will fail to place even on-mesh calls and will complain of a '*Bad file descriptor*' error in the interactive console output.

When the MP device's unique IP address is set from the IVR, the Gateway addresses will be set to be in the same IP subnet with the final octet set to '1' e.g. *10.130.1.1*

By default, the IVR function will set the DNS address to a public server address at *8.8.8.8*

Note: Care must be taken when setting these addresses manually from LUCI or command line.

Access to SIP/VoIP Server

If Asterisk cannot access the network and see the external VoIP host during startup, calls through the service will fail, even if Asterisk is able to register with the service after startup. Calls to mesh devices will work correctly in this scenario, leading to confusion over the status of Asterisk.

This is particularly relevant to MP devices that are connected to the LAN / Internet only via the mesh, as the start up order and timing of scripts in */etc/rc.d* are designed to ensure the mesh is running correctly before Asterisk tries to start.

Sample Asterisk Console Outputs

1. Call from MP at 192.168.1.32 to MP at 192.168.1.22 on the mesh network.

```
MP-32*CLI>
-- event_offhook
-- AST_STATE_DOWN:
-- start mp_new
-- event_dtmf 2
-- event_dtmf 2
-- event_digit_timer
-- extension exists, starting PBX 22
-- Executing [22@default:1] Dial("MP/1", "SIP/4000@192.168.1.22") in new stack
-- Called 4000@192.168.1.22
-- SIP/192.168.1.22-00587578 is ringing
-- Asked to indicate 'Remote end is ringing' condition on channel MP/1
MP-32*CLI>
```

2. Call to a PSTN number 0733991234 via SIP / VoIP Service

```
MP-32*CLI>
-- event_offhook
-- AST_STATE_DOWN:
-- start mp_new
-- event_dtmf #
-- event_dtmf 0
-- event_dtmf 7
-- event_dtmf 3
-- event_dtmf 3
-- event_dtmf 9
-- event_dtmf 9
-- event_dtmf 1
-- event_dtmf 2
-- event_dtmf 3
-- event_dtmf 4
-- event_digit_timer
-- extension exists, starting PBX #0733991234
-- Executing [#0733991234@default:1] Dial("MP/1", "SIP/0733991234@sipaccount|120|r")
-- Called 0733991234@sipaccount
-- Asked to indicate 'Remote end is ringing' condition on channel MP/1
MP-32*CLI>
```